

(No Model.)

3 Sheets—Sheet 1.

A. P. CREQUE.
PLANING MACHINE.

No. 274,565.

Patented Mar. 27, 1883.

Fig. 1.

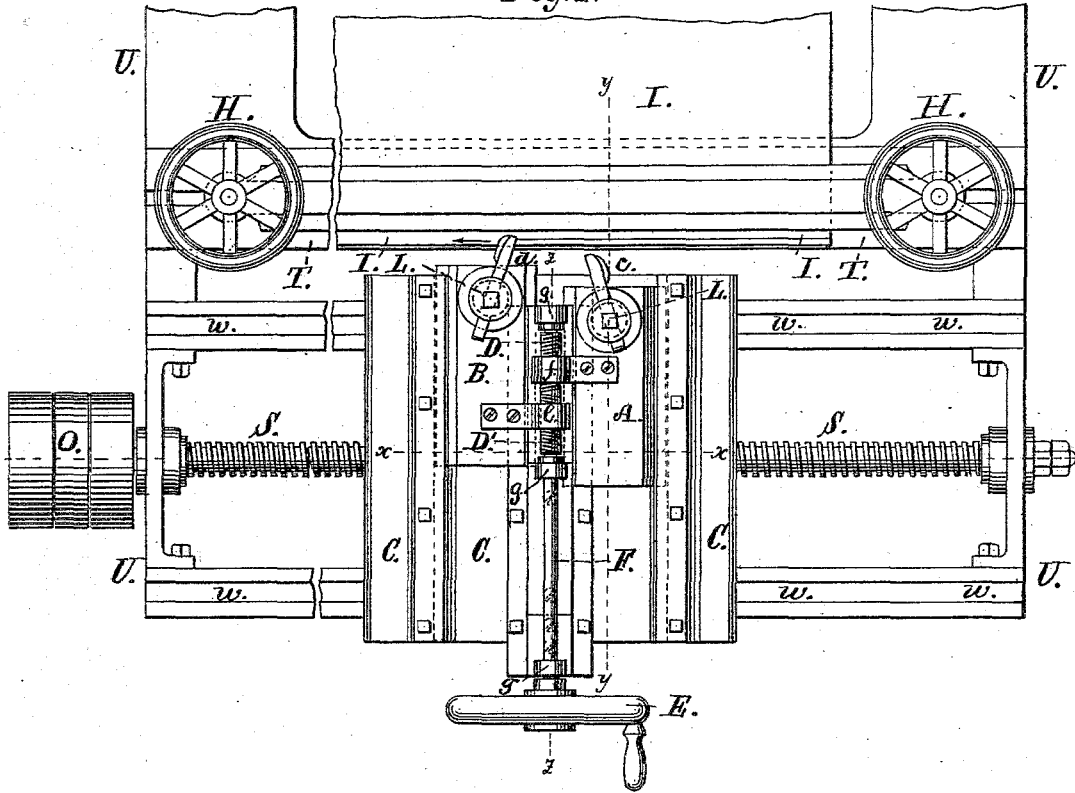
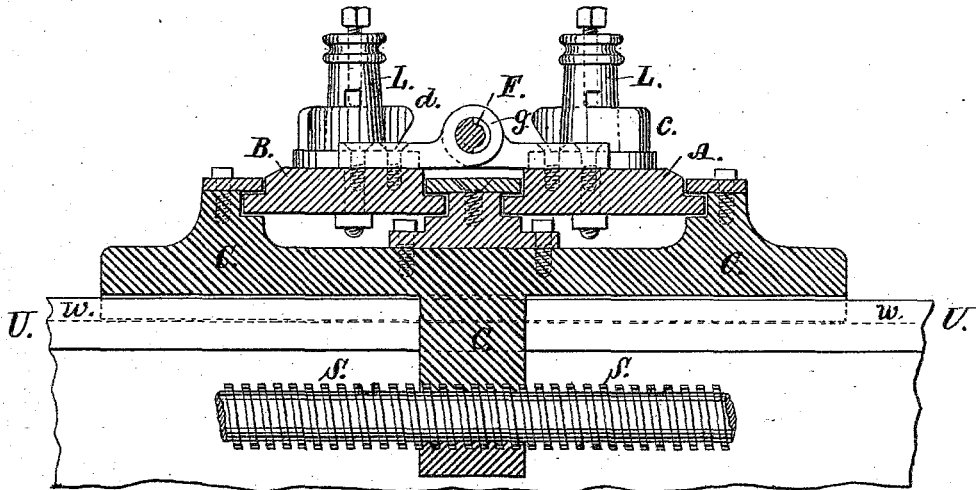

Fig. 2.



WITNESSES =

Thomas Hunt
Fronig W. Spencer

INVENTOR =

Allen P. Creque
by Joseph H. Harwin
his Attorney

(No Model.)

3 Sheets—Sheet 2.

A. P. CREQUE.
PLANING MACHINE.

No. 274,565.

Patented Mar. 27, 1883.

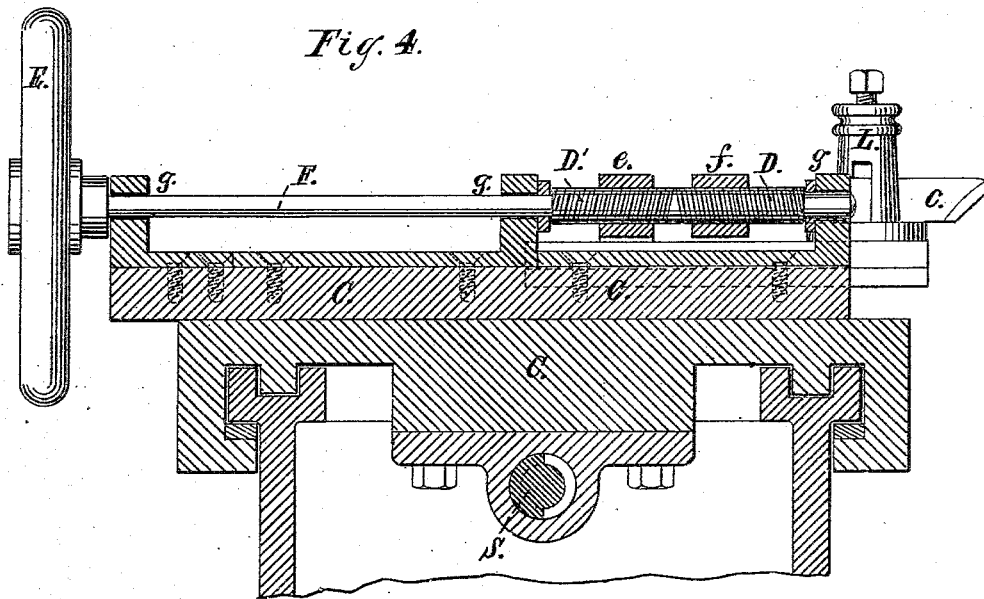
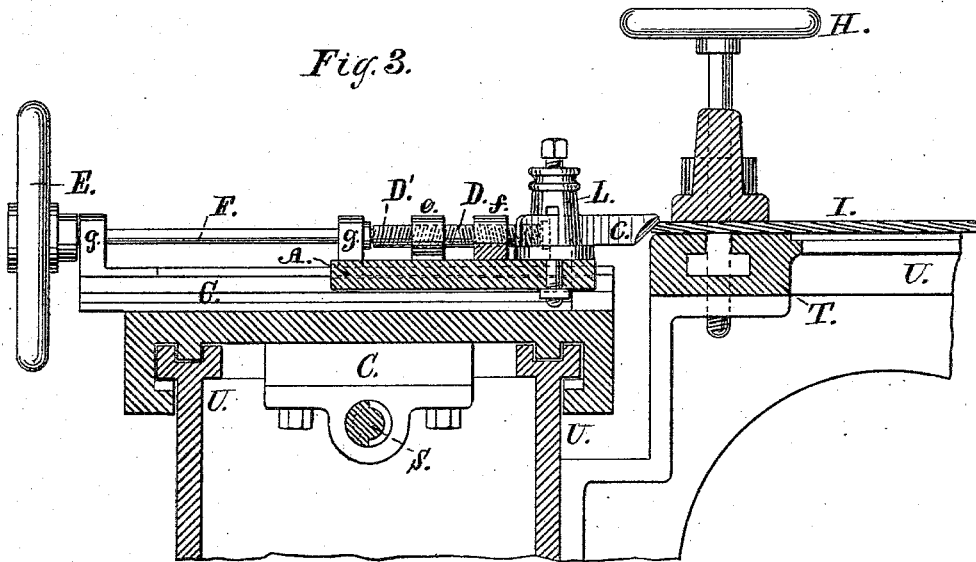

WITNESSES =
Thomas Hunt
Ervin W. D. Persson

INVENTOR =
Allen P. Creque
by Joseph W. Martin
his Attorney

(No Model.)

3 Sheets—Sheet 3.

A. P. CREQUE.
PLANING MACHINE.

No. 274,565.

Patented Mar. 27, 1883.

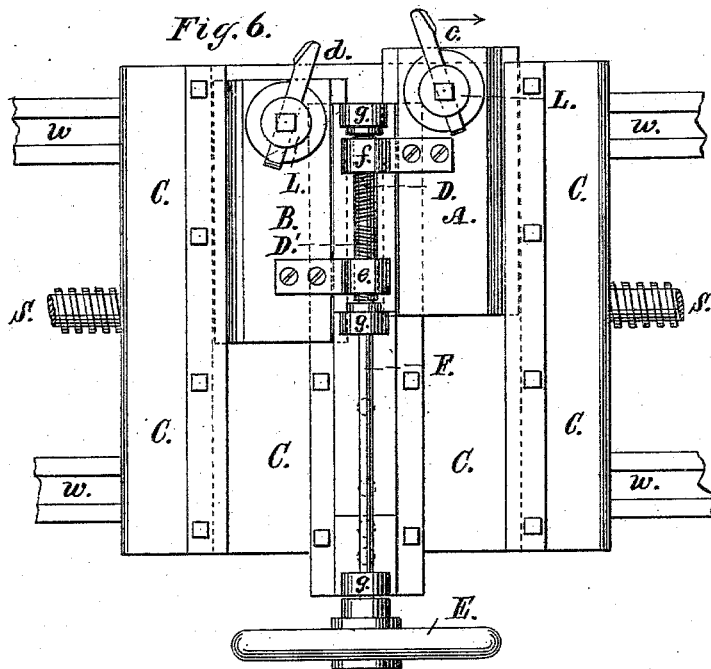
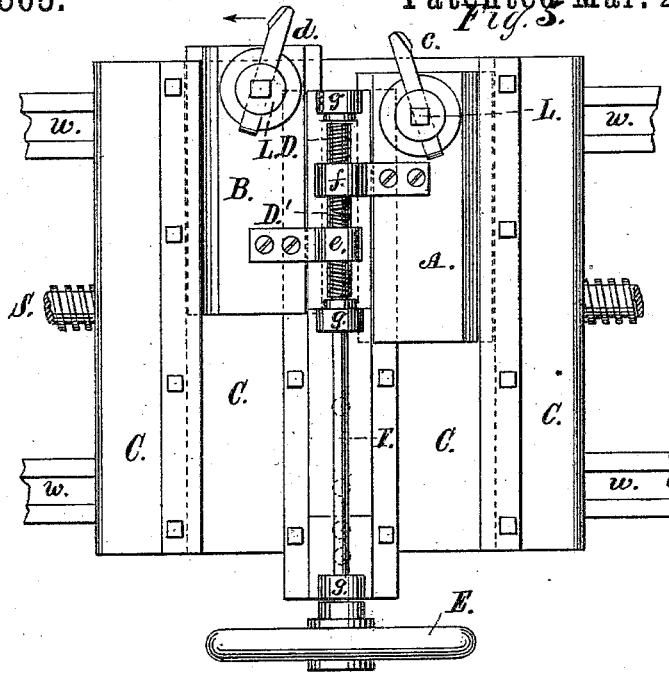

WITNESSES =

Thomas Hunt.
Erving W. Spencer

INVENTOR =
Allen P. Creque
by Joseph H. Martin.
his Attorney

UNITED STATES PATENT OFFICE.

ALLEN P. CREQUE, OF NEW YORK, N. Y.

PLANING-MACHINE.

SPECIFICATION forming part of Letters Patent No. 274,565, dated March 27, 1883.

Application filed August 24, 1882. (No model.)

To all whom it may concern:

Be it known that I, ALLEN P. CREQUE, a citizen of the United States, residing in the city, county, and State of New York, have invented a new and useful Improvement in Planing-Machines, of which the following is a specification.

My invention relates to machines adapted to plane metal and other hard materials, and is also capable of being adjusted so as to be operative upon an ordinary lathe; and the object of my improvement is to save the loss of time which is experienced with the ordinary planing-machines, as now commonly used, owing to the fact that such planes generally have only one cutting-tool, which only cuts while traveling in one direction, so that the time consumed by the tool in returning to the starting-point for a new cut is lost.

I am aware that planing-machines are well known in which two cutting-tools adapted to cut in opposite directions are used; but such tools are usually mounted upon separate heads whose traveling motion is independent of each other. Such machines, however, which are known as the "double-head planing-machines," are very heavy and expensive, while they cannot be adapted to an ordinary lathe. I obviate these disadvantages by the use of the mechanism illustrated in the accompanying drawings, in which—

Figure 1 is a plan view of the entire machine, showing the material in position to be planed. Fig. 2 is a sectional view of Fig. 1 upon the line *xx*. Figs. 3 and 4 are sectional views of Fig. 1 upon the lines *yy* and *zz*, respectively. Figs. 5 and 6 are plan views, showing the position of the planing-tools when in operation.

Similar letters refer to similar parts throughout the several views.

U is the frame of the machine, upon which are supported the bed C and cutting mechanism mounted thereon, and the table T, upon which the material to be planed is secured. The longitudinal screw-shaft S, driven by the drum O, has its bearings in the frame U and upon the shaft S. The bed C, which carries the cutting-tools, travels in ways *ww*. A small shaft, F, which is turned by the hand-wheel E, is mounted in standards *gg*, placed upon the bed C in a direction at right angles

to the shaft S. The end of the shaft F is cut into two screws, D and D', one having a right-hand thread and the other a left-hand thread. Upon these two screws D D' are placed two nuts, *ef*, having flanges, through which they are bolted to the sliding pieces A B, which are thus given a traveling movement upon the bed C in a direction parallel to the shaft F. A and B carry the holders L L, in which the tools *cd* are placed. I is the iron or other material to be planed, and H H are clamps for holding it in position upon the table T. By cutting the end of the shaft F into right and left hand screws it is apparent that a single turn of the shaft causes the respective nuts *ef* to move in opposite directions, and with them the tools *cd*, mounted upon the slides A B, to which the nuts *ef* are bolted.

The operation of the machine is as follows: When the bed C is at one end of the shaft S the shaft F is turned until the tool proper for cutting in that position engages with the surface to be planed, as shown in Fig. 5. The planer then travels along the shaft S until one cut is made. The shaft F is then turned again, withdrawing the tool which has just been used and presenting the other, as shown in Fig. 6. The planer then travels back along the shaft S, making a second cut, and this operation is successively repeated.

Although the machine above described has been shown as a separate machine, it is obvious that by slight modifications, which readily suggest themselves, the described mechanism may be adjusted to be used upon an ordinary lathe with equally beneficial results.

Having thus described my invention, I do not claim, broadly, a planer which will plane in opposite directions; but

I claim—

1. The combination, in a planing-machine, of a table upon which the material to be planed is held and supported with two planing-tools, which are alternately set against the material and operated by mechanism substantially such as described, one of which tools in cutting travels in one direction along the material, and the other of which in cutting travels in the opposite direction, as and for the purposes specified.

2. A planer having a stationary work-hold-

ing bed and two reciprocating planing-tools, each of said planing-tools being alternately set and withdrawn from operation by means of a shaft having two screws cut thereon, one 5 screw having a left-hand thread and the other a right-hand thread, said screws working in flanged nuts, substantially as described.

3. The combination, in a planing-machine, of two planing-tools, *c d*, adapted to cut in op-

posite directions, mounted upon the holders 10 A B, and operated by means of the nuts *e f*, shaft F, and hand-wheel E, all mounted upon the bed C, traveling in ways *w w* upon the shaft S, substantially as described.

ALLEN P. CREQUE.

In presence of—

HARRY E. LEIBOLD,
DAVID MILLIKEN, Jr.